



The ILW Performance Level 'd'/SIL2 series of Gefran are pressure transmitters for using in high temperature environment with IO-Link output.

The main characteristic of this series is the capability to read temperature of the media up to 315°C (600°F).

The constructive principle is based on the hydraulic transmission of the pressure.

The fluid-filled system assures the temperature stability.

This "Smart" transmitter with IO-Link output is ready for "Industry 4.0" requirements.

"ILW" is Gefran's series of high-temperature pressure sensors with filling fluid and digital output.

This new series ILW with "IO-Link" interface is a Smart device specifically designed to meet the requirements of "Industry 4.0" environment, with auxiliary information suitable to prevent machine downtime and thanks to the filling fluid solution it can withstand up to 315°C of process temperature.

In addition, with PLd and SIL2 approvals, the ILW series is the best solution for "functional safety" applications.

### MAIN FEATURES

- Pressure ranges from:  
0-17 to 0-1000 bar / 0-250 to 0-15000 psi
- Accuracy: <math>\pm 0.25\%</math> FS (H); <math>\pm 0.5\%</math> FS (M)
- 1/2-20UNF, M18x1.5 standard threads; other types available on request
- 117-7 PH corrugated diaphragm with GTP+ coating fother types available on request
- Oil filling meets FDA requirements CFR 178.3620 and CFR 172.878
- Stem material: 17-4 PH
- IO-Link output, ready for "Industry 4.0"
- Rangeability: 3:1
- PLd and SIL2 approvals for Functional safety
- Autozero function
- Auxiliary information over IO-Link protocol

*GTP+ (advanced protection)*

*Coating with high resistance against corrosion, abrasion and high temperature*

### AUTOZERO FUNCTION

All signal variations in the absence of pressure can be eliminated by using the Autozero function.

This Autozero function is activated via IO-Link command.

The procedure is allowed only at zero pressure.

### TECHNICAL SPECIFICATIONS

Accuracy (1)	<b>H</b> $\leq \pm 0.25\%$ FS (100...1000 bar) <b>M</b> $\leq \pm 0.5\%$ FS (17...1000 bar)
Measurement range	0..17 to 0..1000bar 0..250 to 0..15000psi
Maximum overpressure (without degrading performances)	2 x FS 1.5 x FS above 700bar/10000psi
Measurement principle	Extensimetric (Thick film)
Power supply	18-30 Vdc
Maximum current absorption (*)	1 W (1.2 W with relay optional)
Zero offset	$\leq \pm 0.25\%$ FS
Zero adjustment	"Autozero" function
Communication interface	IO-Link
Cycle time	2 msec
IO-Link version	1.1
Transmission type	COM2 (38.4 kBaud)
Profile	Smart sensor generic profile
SIO Mode	Yes
Required class for Master port	A
Pressure process data resolution	14 bit
Analog output resolution	16 bit
Temperature process data resolution	16 bit
Rangeability	3:1 (analogue output opt.)
Calibration signal	80% FS
Power supply polarity reverse protection	YES
Compensated temperature range housing	0...+85°C
Operating temperature range housing	-30...+85°C
Storage temperature range housing	-40...+125°C
Thermal drift in compensated range: Zero / Calibration / Sensibility	<math>< 0.02\%</math> FS/°C
Diaphragm maximum temperature	315°C / 600°F
Zero drift due to change in process temperature (zero)	<math>< 4</math> bar/100°C / <math>< 30</math> psi/100°F
Integral temperature (optional)	Accuracy T/C type J
Protection degree (5-pole female connector)	IP65 with suitable mating connector

FS = Full scale output: (1) BFSL method (Best Fit Straight Line); includes combined effects of Non-Linearity, Hysteresis and Repeatability (according to IEC 62828-2).

(\*) does not take into account absorption on DO in SIO mode (limited to 200mA)

# MECHANICAL DIMENSIONS

## ILW0

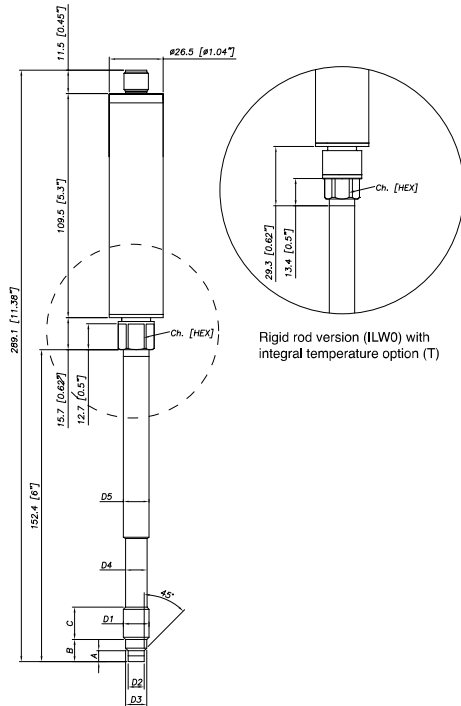

D1	1/2 - 20UNF
D2	$\phi 7.8 -0.05$ [ $\phi 0.31'' -0.002$ ]
D3	$\phi 10.5 -0.025$ [ $\phi 0.41'' -0.001$ ]
D4	$\phi 10.67$ [ $\phi 0.42''$ ]
D5	$\phi 12.7$ [ $\phi 0.5''$ ]
A	$5.56 -0.26$ [ $0.22'' -0.01$ ]
B	$11.2$ [ $0.44''$ ]
C	$15.74$ [ $0.62''$ ]
Ch [Hex]	$16$ [ $5/8''$ ]

## ILW1

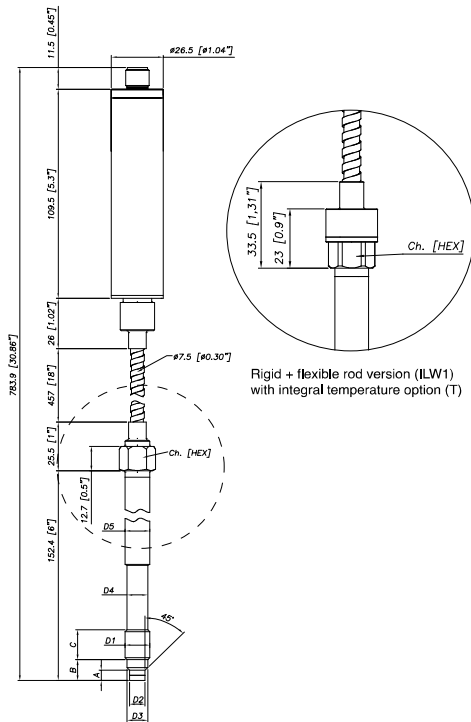

D1	M18x1.5
D2	$\phi 10 -0.05$ [ $\phi 0.394'' -0.002$ ]
D3	$\phi 16 -0.08$ [ $\phi 0.63'' -0.003$ ]
D4	$\phi 16 -0.4$ [ $\phi 0.63'' -0.016$ ]
D5	$\phi 18$ [ $\phi 0.71''$ ]
A	$6 -0.26$ [ $0.24'' -0.01$ ]
B	$14.8 -0.4$ [ $0.58'' -0.016$ ]
C	$19$ [ $0.75''$ ]
Ch [Hex]	$19$ [ $3/4''$ ]

## ILW3

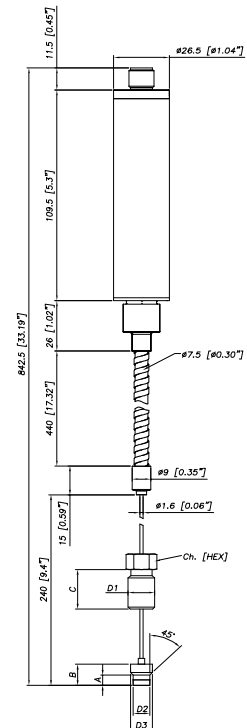

**NOTE :** dimensions refer to rigid stem length option "4" (153 mm – 6")

**WARNING :** For installation use a maximum tightening torque of 56 Nm (500 in-lb)

## SELF DIAGNOSTICS (for SIL/PL certified models only)

Below the conditions detected by the sensor self-diagnostics:

- Cut cable / device non connected / broken power supply, output <3.6 mA/0.25 V
- Pin detachment, output >20.6 mA/10.8 V
- Pressure above 200% of the span, output >20.6 mA/10.8 V
- Voltage monitor in case of overvoltage/undervoltage/voltage variation in the electronics, output <3.6 mA/0.25 V
- Program sequence error, output <3.6 mA/0.25 V
- Overtemperature on the electronics, output <3.6 mA/0.25 V
- Error on the primary element output or on the first amplification stage, output <3.6 mA/0.25 V

## OPTIONAL RELAY OUTPUT FOR EXCESS PRESSURE PROTECTION (for SIL/PL certified models only)

Safety relay characteristics:

- Activation threshold to be defined in the order code
- Rated carry current: 1A
- Rated voltage: 24Vdc  $\pm$  20%
- Switch accuracy: 2 x sensor accuracy
- Hysteresis: 2% FS

SUPPLY	OUTPUT	RELAY STATUS
OFF	-	OPEN
ON	< X%FS	CLOSED
ON	> X%FS	OPEN
ON	under range	OPEN
ON	over range	OPEN

## NAMUR COMPLIANCE (for SIL/PL certified models only)

The sensors are tested according to Namur NE21 recommendations.

The same compatibility is valid for the NE43 Namur recommendation with the following sensor behaviour in case of breakdown:

- Cut cable: breakdown information as the signal is <3.6 mA/0.25 V
  - Device not connected: breakdown information as the signal is <3.6 mA/0.25 V
  - Broken power-supply: breakdown information as the signal is <3.6 mA/0.25 V
- or in case of performance problems:
- most common failures on primary sensors: the signal goes to >20.6 mA/>10.8 V

Note: in all the remaining situations, the output signal is always included between 3.6 mA/0.25 V and 20.6 mA/10.8 V.



**Recommendation:** the error level set by the customer (e.g. maximum pressure value) has to be inside the nominal range

## AUTOZERO FUNCTION

The Autozero function is activated by IO-Link command.

All zero drift caused by temperature change on the tip can be removed by using this function.

This autozero procedure must be performed at zero pressure only, when the sensor is completely installed on the system.

See operating manual for complete Autozero Function explanation

## ELECTRICAL CONNECTIONS

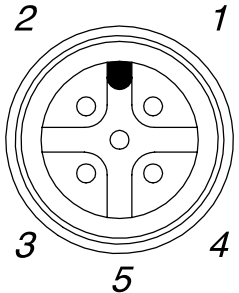
<b>5 pin M12x1 connector</b> 	M12x1 5 pin Connector	IO-LINK Output	Relay Output Option	Analogue Output Option
	1	V+	V+	V+
2	DO (*)	Relay Conctat 1	DO (*)	DO (*)
3	V-	V-	V-	V-
4	IO-LINK	IO-LINK	IO-LINK	IO-LINK
5	N.C.	Relay Conctat 2	Analogue Output	Analogue Output

(\*) DO = digital output only active in SIO mode

## ACCESSORIES

### Connectors

5-pin female connector	<b>CON031</b>
5-pin female connector, angle 90°	<b>CON041</b>

### IO-Link connection cables

IO-Link and Safety output Y splitter cable, 5 pins M12 connector	<b>CAV500</b>
2m unshielded cable, with M12 female 5 pins straight connector and M12 male 5 pins straight connector	<b>CAV501</b>
5m unshielded cable, with M12 female 5 pins straight connector and M12 male 5 pins straight connector	<b>CAV502</b>
10m unshielded cable, with M12 female 5 pins straight connector and M12 male 5 pins straight connector	<b>CAV503</b>

### Master IO-Link

Gefran has analyzed and then qualified the main masters on the market that meet the IEC 61131-9 standard relating to the digital communication interface IO-Link 1.1, and therefore compatible with ILM, ILW, ILK and ILI transducers.

**Note:** For further information (ordering codes, technical specifications, etc.) please contact Gefran or write to: [info@gefran.com](mailto:info@gefran.com).

### Accessories

Mounting bracket	<b>SF18</b>
Dummy plug for 1/2-20UNF	<b>SC12</b>
Dummy plug for M18x1.5	<b>SC18</b>
Drill kit for 1/2-20UNF	<b>KF12</b>
Drill kit for M18x1.5	<b>KF18</b>
Cleaning kit for 1/2-20UNF	<b>CT12</b>
Cleaning kit for M18x1.5	<b>CT18</b>

