



Dimensions 96 × 96 × 80 mm (1/4 DIN)

## MAIN FEATURES

- high impedance input for Zirconium probe reading
- Carbon potential control and Dew Point reading
- Burnoff procedure for cleaning the Zirconium probe, with specific alarm settings to detect any probe malfunctions
- Operator interface with large LCD Display and three configurable bargraphs
- Scrolling diagnostics messages, configurable, in the selected language
- Preventive maintenance with energy counters (kWh) and load switching
- 32 function block applications
- 8 Math application blocks
- Timer, setpoint and algorithm programmer for controlling motorized valves
- Advanced tuning of control parameters
- Different password levels
- Inputs 3 and 1 already set for Zirconium probe (3) and thermocouple (1) readings to calculate the carbon potential
- 2 PID control loops
- 2 setpoint programmers (192 steps in 16 programs, or 12 programs with 16 fixed steps each)
- Relay, logic, isolated analog outputs
- RS485 serial communication in Modbus RTU slave
- RS485 serial communication in Modbus RTU master for reading/writing information to Modbus slave devices
- Ethernet Modbus TCP communication in Slave mode
- Web server for browser access to web pages residing in the device, for monitoring and setting parameters
- Weekly clock/calendar with RTC
- Removable faceplate for immediate replacement
- Accuracy 0,1%, sampling time 60 ms

## PROFILE

### Operator Interface

Large backlit LCD screen with high visibility and high contrast. Two to three rows on the screen display variables, setpoints and alphanumeric information, scrolling up to 75 configurable messages of 32 characters each in three different languages. The selection of languages and easily comprehensible scrolling texts regarding diagnostics, alarms, and process statuses ensure that the controllers speak the users' language.

### Control

The controller uses the temperature and oxygen concentration signals to calculate the carbon potential of the atmosphere in the oven.

The second temperature LOOP may be used to control oven temperature.

The instrument enables automatic or manual cleaning cycles to be carried out on the zirconium oxide oxygen probe (Burnoff).

If the appropriate four-point calibration is performed in the field, the controller meets the requirements of standard AMS2750E and may be used in applications requiring

the NADCAP directive.

### Easy Configuration

Opportunity to create your own password-protected "User menu" containing only the parameters required for the application.

Advanced set-up and work recipe creation can be achieved via PC and GF\_eXpress software, even without powering the controllers. GF\_eXpress may be used to define, for each menu and parameter, which values will be shown to the controller to ensure easy use in the field.

Controllers can still be configured directly in the field using only four keys, associated with led lights that provide feedback when a button is pressed and guide the user by indicating the appropriate operations. Factory settings can be restored if necessary, either on the keyboard or using the GF\_eXpress software tool. Diagnostics, preventive maintenance and consumption monitoring.

Exhaustive diagnostics for breakage or incorrect connection of probes, total or partial load breakdown, off-scale variables and anomalies in the control ring. Counters for the number of relay and comparator switches, with alarm thresholds, permit

scheduling of preventive maintenance to replace worn actuators. Two internal energy counters with alarms for anomalous variations count total energy consumption in kWh and its cost, permitting ongoing energy monitoring.

### Diagnostics, preventive maintenance and consumption monitoring.

Zirconium probe diagnostics measure the impedance value and the response of the probe to a short circuit of the voltage input to check the signal recovery time. There is also an exhaustive diagnostics in the event of breakage or incorrect connection of probes, total or partial breakage of the load, off-scale variables and anomalies in the adjustment ring. Relay switch counters and comparators with alarm signals permit planning of preventive maintenance work for replacement of worn actuators. Two internal energy counters with alarms for signalling anomalous variations totalise energy consumption in kWh and its cost, permitting uninterrupted energy monitoring.

### Functional application blocks

Thirty-two logical AND, OR, Flip-Flop, Comparator, Counter and Timer Function Blocks permit creation of customised logical sequences for complete, flexible machine control. Eight mathematical Function Blocks permit processing of analogue variables and calculation of differences, sums, multiplication and division, averages, top and bottom values, square root calculation and logarithms. The Function Blocks also allow you to manage the 8+8 additional inputs/outputs and 8 relay outputs.

### Tuning

Advanced temperature loop tuning algorithms guarantee stable, accurate control even with critical or very rapid thermal systems, automatically activated when necessary.

### Timers

Three different types of timer permitting waiting times to be set before activating control, maintenance times on setpoint values, and scheduled set changes over time.

### Setpoint programmers

Up to 192 steps are available for applications with setpoint profiles, each with a ramp and maintenance time, which

can freely be grouped into up to 16 programmes. Each segment may be associated with enabling inputs, event outputs, and configurable messages to be displayed. In models 1850CC, the display also permanently shows the step number and programme number underway. Double programmer mode, with a synchronous or asynchronous timing base, permits activation of two different setpoint profiles which may be independent of one another and may be associated with two control loops. The clock/weekly calendar function with a real-time clock and buffer battery facilitate starting and stopping of various programmes in default automatic mode.

Simplified keyboard configuration permits creation and editing of simple programmes with only three parameters per step, with no need for a PC, cables, or configuration software, while the extended configuration with Gf\_eXpress also offers graphic functions for displaying the profiles created.

### Valve positioner

Models are available for motorised valve control, with or without position feedback. The position of floating valves is calculated; for valves with potentiometers, auxiliary inputs can be used to control valve position and display it in numerical form or in one of 3 configurable bar graphs (for

models 1650CC/1850CC)

### Connectivity

1650CC/1850CC "Carbon Controller" controllers have three different levels of communication with automation and supervision devices:

- RS485 Modbus RTU slave serial communication for interface with Master Modbus
- RS485 Modbus RTU master serial communication for reading/writing information toward Modbus slave devices such as power controllers or other controllers
- RJ45 Ethernet Modbus TCP port, which can also be used as a bridge toward Modbus RTU slave devices.

An Ethernet connection may be used to access the Web Server service offering a number of monitoring, diagnostics and configuration pages, accessible via local or remote networks with an ordinary browser and two password levels.

### General features

Carbon Controller controllers are entirely configurable using the software and keyboard, without accessing their internal electronics, but the controller can be replaced at any time by simply pulling it out from the front, with no further operations, maintaining IP65 protection for the front.

## DISPLAY AND KEYS

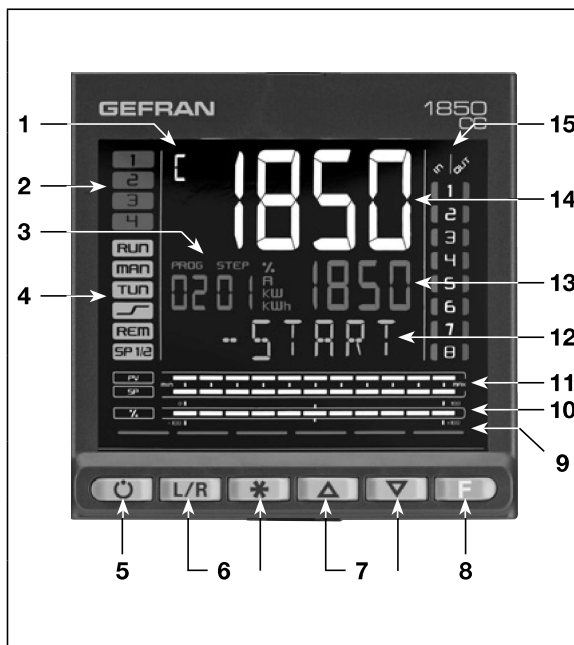

- 1 Carbon percentage
- 2 State of outputs OUT1, OU2, OUT3, OUT4.
- 3 Displays program number, step number, unit of measurement (% , A, kW, kWh).
- 4 Controller function states:
  - RUN = functioning (flashing = normal functioning, steady on = program running);
  - \_/- = setpoint ramp active;
  - TUN = PID parameters tuning active;
  - MAN = manual/automatic (off=automatic control, on = manual control);
  - REM = remote setpoint enabled;
  - SP1/2 = setpoint active (off = setpoint 1, on = setpoint 2).
- 5 Work mode key (manual/automatic) in standard mode. A function can be assigned via parameter but1. The key is active only when the display shows the process variable.
- 6 Key function configurable with parameters but2 and but3. The keys are active only when the display shows the process variable (HOME).
- 7 Up/down keys: raise/lower the value of the parameter displayed on the SV or PV display.
- 8 F key: lets you navigate among controller menus and parameters. Confirms the parameter value and selects the next parameter.
- 9 Key pressed signals.
- 10 Displays percentage of power or current, configurable with parameter bAr3.
- 11 Display of percentage of process variable and of setpoint
- 12 F display: parameters, diagnostics and alarm messages. Configurable with parameter dS.F (default = % control power).
- 13 SV display: parameter values. Configurable with parameter dS.SP (default = setpoint).
- 14 PV display = Process variable
- 15 Display of inputs/outputs state (only with 8 INS/OUTS and/or 8 relays).

# DRILLING DIMENSION AND TEMPLATES

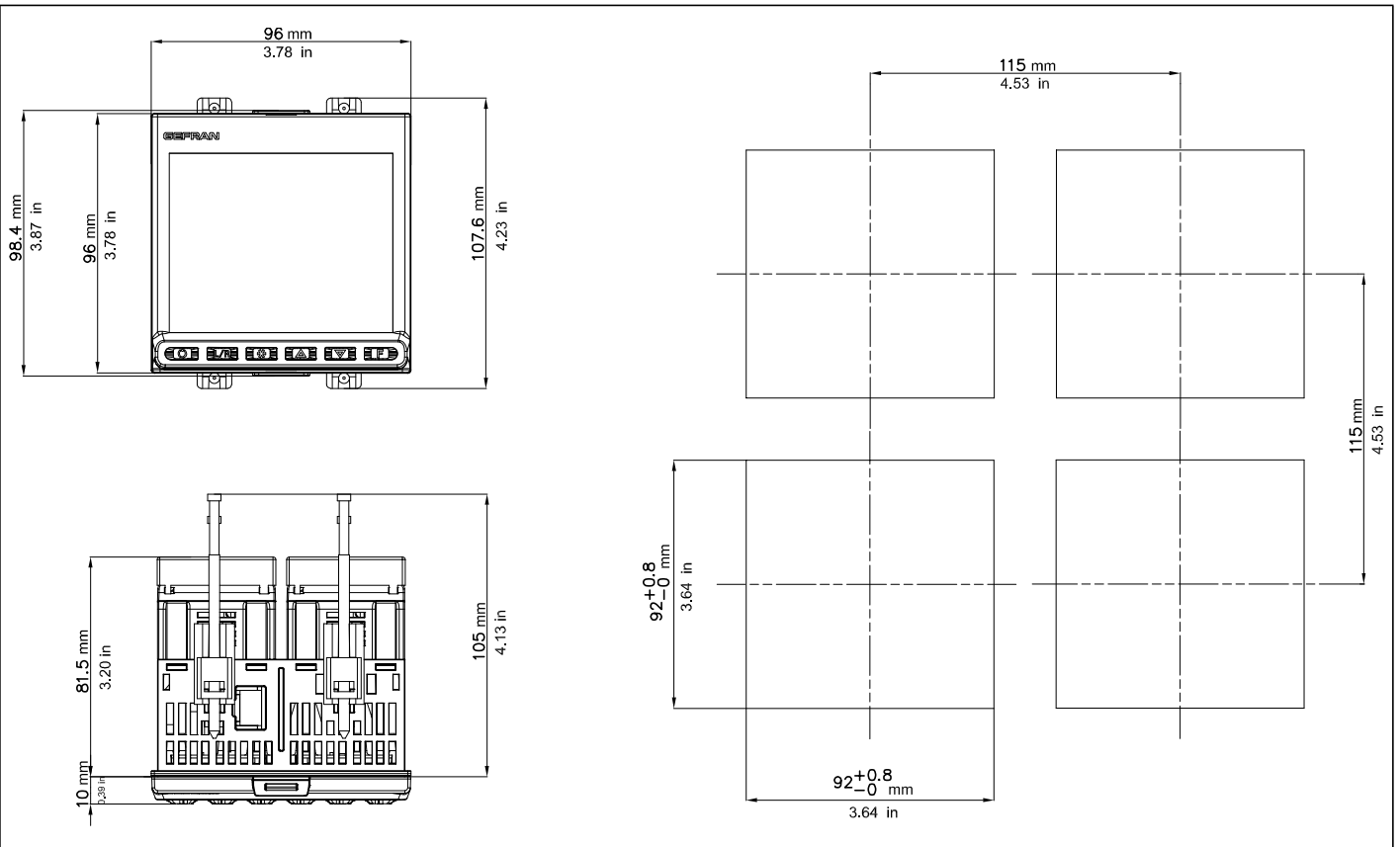

## TECHNICAL DATA

<b>OPERATOR INTERFACE</b>		
<b>DISPLAY</b>	Type	LCD black background
	Screen area (L x H)	83 x 68 mm
	Lighting	Backlit with LEDs, life > 40,000 hours @ 25°C (with brightness level backl = 0.8)
	PV display	Number of digits: 4 to 7 segments, with decimal point Digit height: 23 mm Color: white
	SV display	Number of digits: 4 to 7 segments, with decimal point Digit height: 11 mm Color: green
	F display	Number of digits: 7 to 14 segments, with decimal point Digit height: 9 mm Color: amber
	Unit of measurement	Selectable, °C o °F Color: same as PV display
	Controller state signals	Number: 6 (RUN, MAN, _/-, REM, SP1/2) Color: amber
	Output state signals	Number: 4 (1, 2, 3, 4) Color: red
	Bargraph indicator, configurable	Type: graphic bargraph, 11 segments Power indication: 0...100% or -100...100% Current indication: 0...100% f.s. Valve position indication: 0...100%
	Bargraph indicator	Type: double bar, 11 segments Indication of process variable and setpoint: 0...100% f.s.
Inputs/outputs state signal (only with option)	Number: 8 inputs, 8 outputs Color: green for inputs, red for outputs Control via FB outputs	
<b>KEYPAD</b>		Keys number: 6, silicone (Man/Auto, L/R, *, INC, DEC, F) Type: mechanical
<b>INPUTS</b>		
<b>MAIN AND AUXILIARY INPUT (Main, Aux1, Aux2)</b>	Zirconium probe input (AUX2)	<ul style="list-style-type: none"> <li>- 0...2.4V high impedance</li> <li>- Input impedance: &gt; 100 MΩ</li> <li>- Linearisation: linear or custom</li> <li>- Calibration accuracy: &lt; 0.1% full scale</li> <li>- Thermal shift: &lt; ±0.003% full scale/°C starting from 25°C room temperature</li> <li>- impedance reading (0..100kΩ)</li> </ul>
	Sensor type	<ul style="list-style-type: none"> <li>• Thermocouples, RTD (PT100, JPT100), IR pyrometers with type K output, 4...20mA, 0...20mA, 10V, 5V, 1V, 60mV, potentiometer</li> <li>• Reading accuracy: ±0.1% of value read</li> </ul> <p>This Gefran controller, when subjected to the necessary calibration operations in the field, is suitable for use in Nadcap applications for any class of oven, from 1 to 6, according to specification AMS2750E, paragraph 3.3.1.</p>
	Thermocouple (only Main and Aux1)	<ul style="list-style-type: none"> <li>• Types: J, K, R, S, T, C, D, B, E, L, L-GOST, U, G, N, Pt20Rh-Pt40Rh Custom linearisation available</li> <li>• Linearisation accuracy: according to standard ITS90 polynomes; refer to user manual for details</li> <li>• Cold joint accuracy: &lt; ± 1°C at 25°C ambient temperature</li> <li>• Cold joint compensation: greater than 40:1, rejection at changes in room temperature exceeding 25°C</li> <li>• Diagnostics: Indication of faulty probe and out of scale</li> </ul>
	RTD input (Pt100 and JPt100)	<ul style="list-style-type: none"> <li>• Types: Pt100, JPt100. Custom linearisation available</li> <li>• Calibration accuracy: &lt; ±0,1% of the value read in °C ± 0,4°C</li> <li>• Linearisation accuracy: &lt;±0,062°C</li> <li>• Thermal shift: &lt; (±0.002% of read value/°C, starting from 25°C room temperature) ± 0.1°C</li> <li>• Diagnostics: Indication of faulty probe and out of scale</li> </ul>

<b>MAIN AND AUXILIARY INPUT (Main, Aux1, Aux2)</b>	Linear DC input	<ul style="list-style-type: none"> <li>• Tipi : 0...60 mV, 0...20mA, 4...20mA, 0...1V, 0...5V, 0...10V, 0...2.4V high impedance, 0...1.2V high impedance</li> <li>• Input impedance : <ul style="list-style-type: none"> <li>0...60mV, 0...1V, 0...1.2V, 0...2.4V : &gt; 100 MΩ</li> <li>0...5V, 0...10V : &gt; 400 kΩ</li> <li>0...20mA, 4...20mA : 50 Ω</li> </ul> </li> <li>• Linearisation: linear or custom</li> <li>• Calibration accuracy: &lt; 0,1% out of scale</li> <li>• Thermal shift: &lt;±0.003% full scale/°C, starting from 25°C room temperature</li> </ul>
	Sampling time	60 ms or 120 ms, selectable
	Digital filter	0,0...20,0 s configurable
	Rejection to network disturbance (48-62Hz)	Rejection to differential mode: >80 dB Rejection to common mode: >150 dB
	Temperature unit of measure	Grade °C/°F, selectable on the keypad
	Reading interval	Type: linear Scale: -1999...9999, settable decimal point
	Insulation	Functional insulation between main and auxiliary inputs
<b>TA (ammeter) input</b>	Type	Isolated via external transformer
		Number: 2 max Max. capacity: x / 50 mA AC Line frequency: 50/60 Hz Input impedance (Ri): 10 Ω
	Accuracy	±2% f.s. ±1 digit @25 °C
<b>DIGITAL INPUTS</b>	Number	5
	Type	voltage-free contact, or NPN 24 V - 4,5 mA, o PNP 12/24 V - max 3,6 mA <i>For detail see electrical connections</i>
	Isolation	250 V
<b>OUTPUTS</b>		
	Relay (R)	Number: 4 max Type of relay contact: NO Max. current: 5A (2A at ambient temperature up to 45 ° C for certification UL), 250VAC /30 VDC, cosφ = 1 Minimum load: 5 V, 10 mA Number of operations: > 600,000 @ 2A load current Double isolation Installation of an external R-C suppressor ("snubber") is recommended
	Logic (D)	Number: 2 max Type: for solid-state relays Voltage: 24 V ±10% (min 10 V @20 mA) Isolated from main input
	Isolated logic (M)	Number: 2 max Type: MOS optoisolated for PLC inputs and AC/DC load Voltage: 30 V AC/DC max Current: 100 mA max Resistance ON: 0,8 Ω max Isolation: 1500 V
	Triac ( long life relè) (T)	Number: 1 max Load: resistive Voltage: 75...240 VAC Current max: 1 A Isolation 3 kV Snubber circuit integrated Zero crossing switching
	Continuous (C)	Number: 1 max Current: 4...20mA R <sub>out</sub> < 500 Ω Resolution: 12 bit Isolated from main input
	Analog retransmission (A1) (A2)	Number: 2 max 0...10 V, max 20 mA, R <sub>out</sub> : > 500 Ω 0...20 mA, 4...20 mA, R <sub>out</sub> : < 500 Ω Resolution: 12 bit Isolated from main input

<b>ALARMS</b>	Number of alarm functions	4 max, assignable to an output
	Possible configurations	Maximum, minimum, symmetric, absolute/relative, exclusion at firing, memory, reset from keypad and/or contact, LBA, HB, HBB Hold Back Band if enabled with Programmer function, alarm after power variation at full power Zirconium probe diagnostics alarms, both during operation and when cleaning the probe
<b>POWER SUPPLY</b>	For sensor VT1, VT2	Voltage: 24 VDC $\pm$ 10% Current max: 30 mA VT1 option of Out3
	For potentiometer VP	Voltage: 1 VDC $\pm$ 1% Current max: 30 mA
<b>INPUTS / OUTPUTS</b>		
	Digital Inputs/Outputs	Number: 8, in two groups (5 + 3 with separate power supply) Input: PNP 24 VDC, 5 mA Output: PNP with 24 VDC external power supply, $\pm$ 25%, max 100 mA, short circuit protection with PTC Isolation: 250 V
	Relay	Number: 8, in two groups (5 + 3 relays with common contact) Type of relay contact: NO Max. current: 5A (at ambient temperature up to 45 ° C for certification UL), 250VAC / 30VDC, $\cos\phi = 1$ Max. current for each common: 5 A Number of operations: > 600,000 @ 2A load current Double isolation Installation of an external R-C suppressor ("snubber") is recommended
<b>CONTROL FUNCTIONS</b>		
<b>CONTROL</b>	Type	Single/Double loop
	Control	PID, ON/OFF, single action heat or cool, double action heat/cool
	Control output	Continuous or ON/OFF Cycle time: constant or optimized (BF)
	Control output for motorized valves	OPEN/CLOSE for floating motorized valve or with feedback with position control by potentiometer on Relay, Solid-state, Triac outputs.
<b>SETPOINT PROGRAMMER (Double programmer if double loop)</b>	Number of programs	Max 16 (if double loop 8 + 8) (*) Start / Stop / Reset / Skip via digital inputs and/or outputs from logic operations Output state: Run /Hold / Ready / End
	Number of steps	Max 192, each with own setpoint, ramp time and hold time Times settable in HH:MM or MM:SS Max 4 consents, configurable for ramp and for hold Max 4 events, configurable in ramp and in hold
<b>MULTIPLE SETPOINTS</b>	Number of setpoints	Max 4, selectable from digital input Each setpoint change is subject to set ramp, different for up and down ramp
<b>LOGIC <sup>1</sup> OPERATIONS</b>	Digital function blocks	Max 32, with 4 input variables per block. The result can act on the state of the controller, of the programmer on alarms and outputs. Each function has an AND, OR with TIMER block
<b>OPERATIONS MATHEMATICAL <sup>1</sup></b>	Analog function blocks	Max 8, with 2 input variables per block, with operators such as + , - , $\times$ , : , average, square root, ... The result may act on analog variables in input to PID loops (controlled variable, setpoint) or analog outputs .
<b>TIMER FUNCTION</b>	Modes	START / STOP (2 timer if double loop) STABILIZATION (timer is on when PV enters a band set around setpoint; at end of count you can activate an output, shut down SW or change SP1/SP2) FIRING (timed activation of control after power on)

<b>DIAGNOSTIC</b>		Short circuit or open circuit (LBA alarm) Interrupted or partially interrupted load (HB alarm) Short circuit of control output (SSR alarm)
<b>RETENTIVE MEMORY</b>	Type	FRAM
	Writes	Number max: > 10 <sup>10</sup> cycles Retention: > 10 years

(\*) if in standard mode; if in "Simplified programmer" mode, Max 12 programs

freely selectable in any program, if in standard mode; if in "Simplified programmer" mode, MAX 16 steps per program, in a set order: Program 1 Step 1-16, Program 2 Step 17 – 32, and so on

<b>GENERAL DATA</b>		
<b>POWER SUPPLY</b>	Operating voltage	100...240 VAC/VDC ±10%, 50/60 Hz (20...27 VAC/VDC ±10%, 50/60 Hz)
	Power dissipation	12 W max
	Protections	Overvoltage 300 V / 35 V
	Connection	Screw terminals and crimp connector, max. wire section 1 mm <sup>2</sup>
<b>CONNECTIONS</b>	Serial configuration port	Connector: microUSB
	RS485 (option)	Baudrate: 1200, 2400, 4800, 9600, 19.200, 38.400, 57.600, 115.200 bit/s Protocol: Modbus RTU Insulation compared to main entrance Screw terminals and crimp connector, max. wire section 2.5 mm <sup>2</sup>
	Master Modbus	Baudrate: 1200, 2400, 4800, 9600, 19.200, 38.400, 57.600, 115.200 bit/s Protocol: Modbus RTU Master Connettore RJ10
	RTU Bridge	Baudrate: 1200, 2400, 4800, 9600, 19.200, 38.400, 57.600, 115.200 bit/s Protocol: Modbus RTU Master Screw terminals and crimp connector, max. wire section 2,5mm <sup>2</sup>
	Ethernet Modbus TCP e Webserver (opzione)	Baudrate : 10/100BaseTX, 10/100Mbit/s Protocol : Modbus TCP slave, Webserver integrato Isolation from other peripherals Standard RJ45 connector
	Inputs and outputs	Screw terminals and crimp connector, max. wire section 2.5 mm <sup>2</sup>
<b>AMBIENT CONDITIONS</b>	Use	Internal
	Altitude	2000 m max
	Operating temperature	-10 ... +55 °C (as per IEC 68-2-14)
	Storage temperature	-20 ... +70 °C (as per IEC 68-2-14)
	Relative humidity	20...85% RH non condensante (as per IEC 68-2-3)
<b>PROTECTION LEVEL</b>		IP 65 on front panel (as per IEC 68-2-3)
<b>ASSEMBLY</b>	Positioning	On panel, removable faceplate
	Installation regulations	Installation category: II Pollution degree: 2 Isolation: double
<b>DIMENSIONS</b>		96 X 96 mm (1/4 DIN) Depth: 80 mm
<b>WEIGHT</b>		0,24 kg
<b>CE STANDARDS</b>	EMC (electromagnetic compatibility)	Conforms to Directive 2014/30/EU norme EN 61326-1 Emissions in industrial environment class A
	LVD safety	Conforms to Directive 2014/35/EU norme EN 61010-1
<b>CERTIFICAZIONI</b>	Generals	This Gefran controller, when subjected to the necessary calibration operations in the field, is suitable for use in Nadcap applications for any class of oven, from 1 to 6, according to specification AMS2750E, paragraph 3.3.1.
	Europe	CE, RoHS, REACH
	USA, Canada	UL, cUL
	Russia	EAC

**ACCESSORIES**

Code	Description	Compatible	
		1650CC	1850CC
<b>F060800</b>	Cable for programming with PC, USB-TTL 3 V with USB – microUSB connectors, length 1.8 m	•	•
<b>F043958</b>	“GF_eXpress” software CD	•	•
<b>F060909</b>	Configuration kit for new instruments GF_eXK-3-0-0	•	•
<b>51968</b>	Rubber gasket 48×48 front-box		
<b>51969</b>	Rubber gasket 48×96 front-box	•	
<b>51970</b>	Rubber gasket 96×96 front-box		•
<b>51292</b>	Rubber gasket 48×48 box-panel		
<b>51068</b>	Rubber gasket 48×96 box-panel	•	
<b>51069</b>	Rubber gasket 99×96 box-panel		•
<b>51250</b>	Fastening box to panel		
<b>49030</b>	Fastening box to panel	•	•
<b>51294</b>	Protection of contacts at box bottom		
<b>51328</b>	Protection of contacts at box bottom	•	•
<b>51454</b>	18 contacts at box bottom		
<b>51453</b>	24 contacts at box bottom		
<b>51738</b>	36 contacts at box bottom	•	•



# CONNECTION DIAGRAMS

with option OUT1  
Master Modbus (B) = G

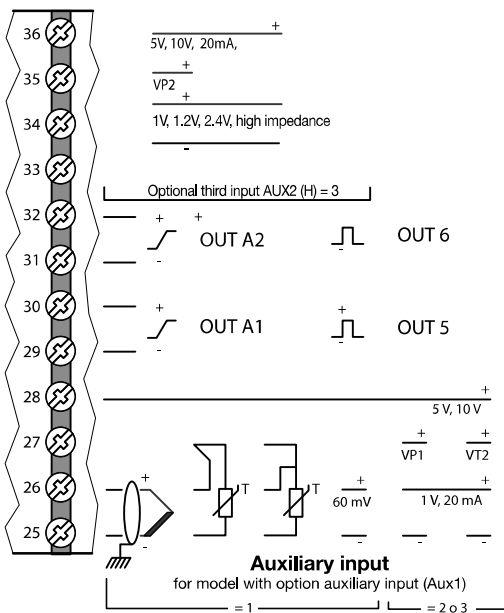
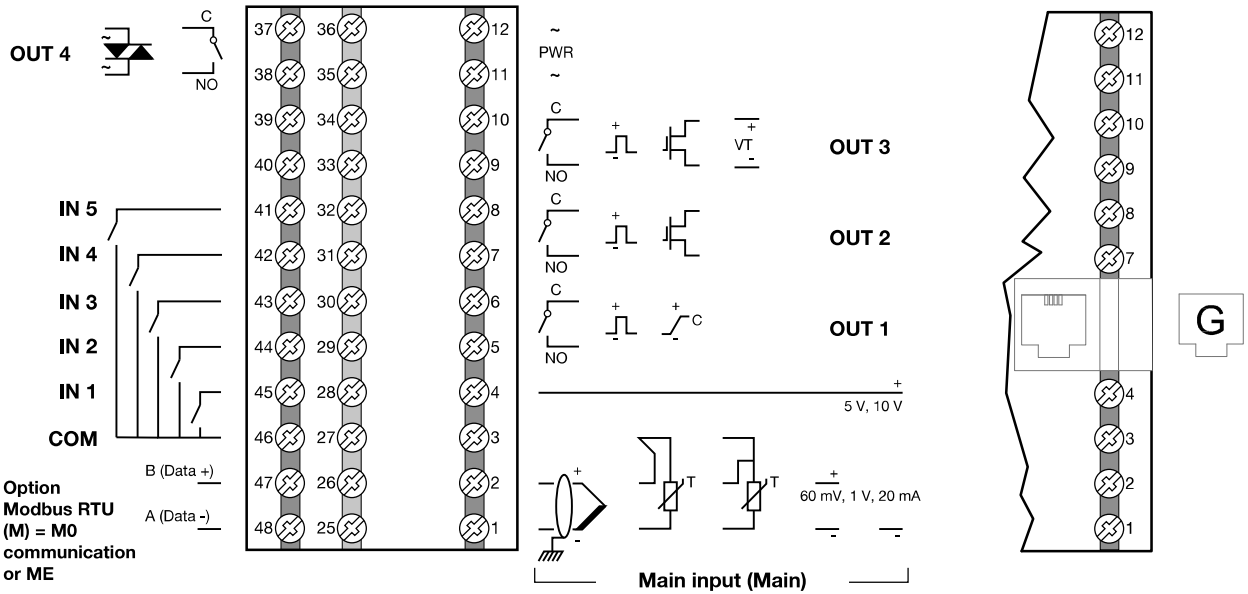

With Ethernet communication option (M) = E0 or ME

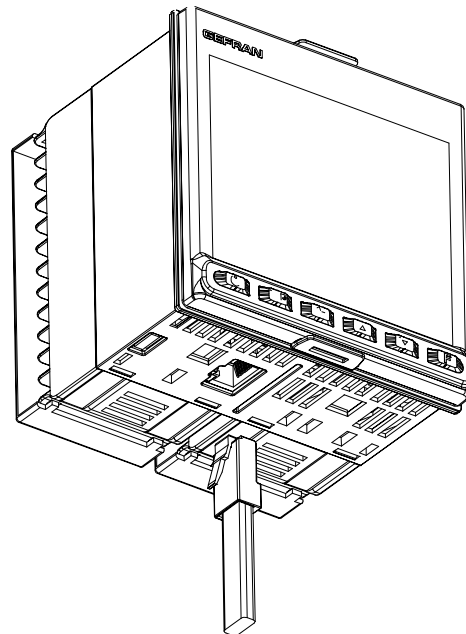

## LEGEND

~ PWR Power supply	 Isolated digital inputs	 Relay output	<u>B (Data +)</u> RS485 serial line
+ - Linear input in voltage / current	 Thermocouple input	 Logic output	<u>A (Data -)</u>
 Input for current transformer	 Input PT100 JPT100 2 / 3wires	 Isolated logic output	+ VT - Supply transmitter
		 Isolated analog output	+ VP - Supply potentiometer



**ATTENTION:** For correct installation, read the warnings contained in the user manual.

## ORDERING CODE

Ordering code: **1850CC** X - X - X X X - 0 - X - 3 X - 5 - X X - X X - X - X X

### Model (A)

Controller	
Programmer	P
Valve (1)	V
Programmer+valve (1)	PV

### Output 1 (B)

Relay	R
Logic	D
Analog	C
Master Modbus RTU communication	G

### Output 2 (C) Output 3 (D)

Relay - Relay	R R
Logic - Logic	D D
Isolated logic - Isolated logic	MM
Relay - VT 24 V	R V
Logic - VT 24 V	D V
Isolated logic - VT 24 V	M V

### Output 4 (E)

Absent	0
Relay	R
Long Life relay	T

### Retransmission (G)

Absent	0
Analogue A1	1
Analogue A1 + A2	2
Analogue A1 + Logic out D6	3
Logic out D5 + Logic out D6	4

### Notes

- 1) Only with option (C) = R and (D) = R
- 2) The option (N) require option (P) =FB or CK

### Fonction (P)

00	Absent
FB	Logical + mathematical operations
CK	RTC + Logical operations + mathematical

### Supply (O)

0	20...27 VAC / VDC
1	100...240 VAC / VDC

### I/O opzionali (N)

00	Assenti
10	8 IN/OUT (2)
01	8 relè (2)
11	8 IN/OUT + 8 relè (2)

### Communication (M)

00	Absent
M0	RS485 Modbus RTU (slave)
E0	Ethernet Modbus TCP
ME	Ethernet Modbus TCP / RS485 bridge

### Digital inputs (L)

5	5 DI
---	------

### Auxiliary input (I)

1	Input Aux : TC, RTD, 60mV
2	Input Aux: 1V/5V/10V/20mA + VP 1 V
3	Input Aux : 1V/5V/10V/20mA + VT2 24 V

### Zirconium probe input (H)

3	3° Input Aux + VP 2 1 V
---	-------------------------

GEFRAN spa reserves the right to make any kind of design or functional modification at any moment without prior notice.

<b>UL</b>	Conformity C/UL/US File no. E216851
<b>CE</b>	EMC: Compliance with Directive 2014/30 / EU, with reference to EN 61326-1 emission in industrial environment class A Security LVD: Compliance with Directive 2014/35 / EU, with reference to EN 61010-1
<b>EAC</b>	
<b>RoHS</b> ✓	

### GEFRAN spa

via Sebina, 74  
25050 PROVAGLIO D'ISEO (BS) - ITALIA  
tel. 0309888.1 - fax. 0309839063  
Internet: <http://www.gefran.com>

# GEFRAN

DTS\_1850CC\_06-2021\_ENG