



Main characteristics

- Magnetostrictive technology
- Strokes from 50 to 1500 mm
- Optimized mechanical structure
- Rod, nipple, exagonal flange AISI 316
- Work temperature: -20...+75°C
- Resistance to vibrations (DIN IEC68T2/6 12g)
- Power supply 24Vdc ± 20%
- Protection IP67
- Electromagnetic compatibility EMC 2014/30/EU
- Compliant to the directive RoHS 2011/65/EU

Contactless linear position transducer with magnetostrictive technology.

The absence of electrical contact on the cursor eliminates all wear and guarantees almost unlimited life.

The analog interface, available with different voltage ranges or in current, with direct and reverse output guarantees greater flexibility of installation and adaptation to pre-existing systems.

High accuracy of the measurement with reference to the non linearity, repeatability and hysteresis. High resistance to vibrations, mechanical shocks for use in a harsh industrial environment.

TECHNICAL DATA

Model	from 50 to 1500 mm
Measurements	displacement
Position read sampling time (typical)	From 1 ms to 1.5 ms (depending on stroke)
Shock test DIN IEC68T2-27	100g - 11ms - single shock
Vibration DIN IEC68T2-6	12g / 10...2000Hz
Displacement speed	≤ 10 m/s
Max. acceleration	≤ 100 m/s ² displacement
Resolution	Infinite
Cursor	Floating separate cursor
Working temperature	-20...+75°C
Storage temperature	-40...+100°C
Coefficient of temperature	≤ 0,01% F.S./°C
Protection	IP67
Operative pressure	350 bar (peak max. 500 bar)

ELECTRICAL DATA

Output signal	0...10.V 10...0 V (A)	4...20mA 20mA ...4mA (E)
Nominal power supply	24 Vdc ±20%	24 Vdc ±20%
Max. power ripple	1Vpp	1Vpp
Max. consumption	35mA	70mA
Load on output	≥ 10kΩ	50... 500Ω
Max. output value	12V	30mA
Alarm output value	10.5V	21mA
Electrical isolation (*)	500V	500V
Protection against polarity inversion	YES	YES
Protection against overvoltage	YES	YES
Protection against power supply on output	YES	YES

(*) It includes 31V 1,7J voltage suppressor

ELECTRICAL / MECHANICAL DATA

Model	Stroke (mm)															
	50	100	130	150	200	400	450	500	600	700	750	800	900	1250	1500	
Sampling time	ms	225	300			1000										
Dimensions Max. (A)	mm	Model +178.2										Model +183.2				
Electrical stroke	mm	Model														
Independent linearity		stroke > 250 mm with sliding cursors ≤ ± 0,04%F.S. (Min. ± 0,090 mm) stroke 50...250 mm with sliding cursors ≤ ± 0,150 mm														
Repeatability	mm	< 0.02														
Hysteresis	mm	< 0.01														

MECHANICAL DIMENSIONS

Strokes from 50 to 1000 mm

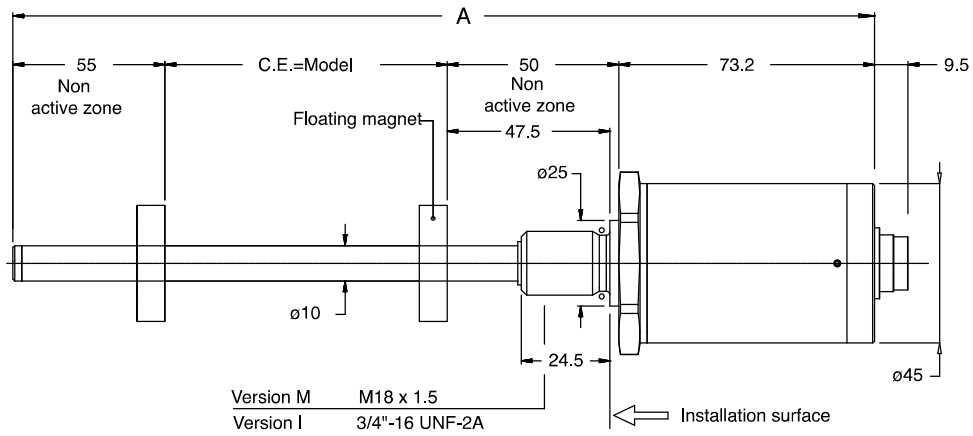

Strokes from 1250 to 1500 mm

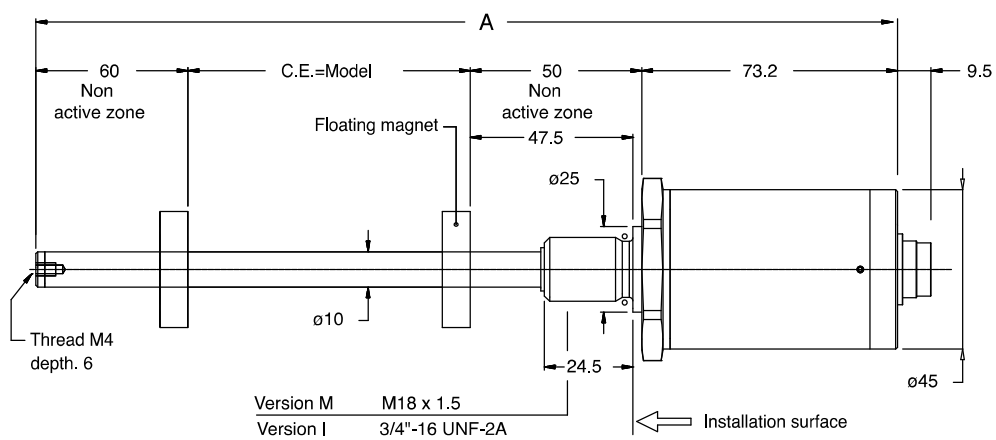

WRG-A-A/B connector output

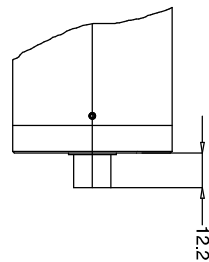

MOUNTING INSIDE A CYLINDER

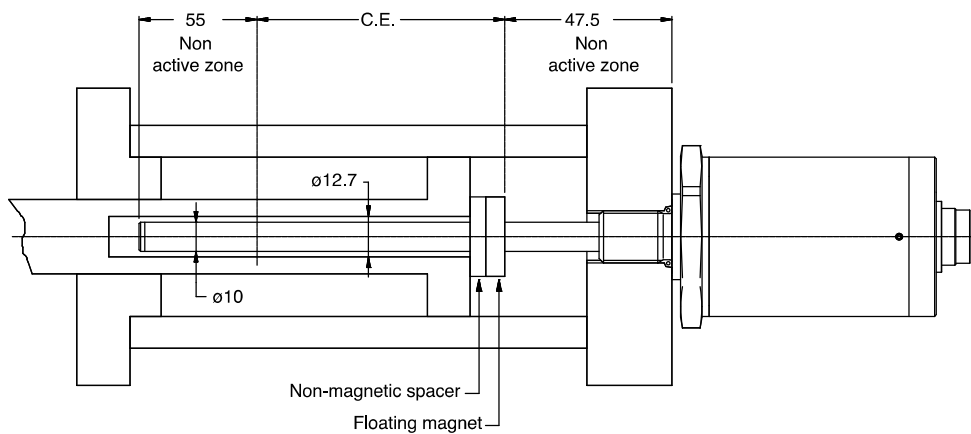

INSTALLATION INSIDE A CYLINDER

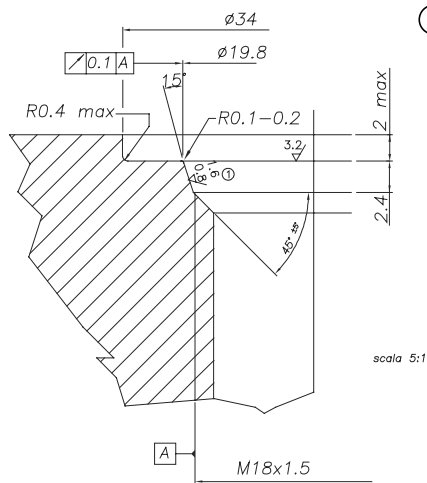

① THREAD M18x1,5

The sealing surface must be free from scratches longitudinal or spiral
 Ro 1.6 μm for sealing with NON-pulsating pressure
 Ro 0.8 μm for seals with pulsating pressure

Suggested o-ring:

PARKER 6-349 15,4x2,1
 Material: Viton 90° Shore-A
 Mixes: PARKER N552-90

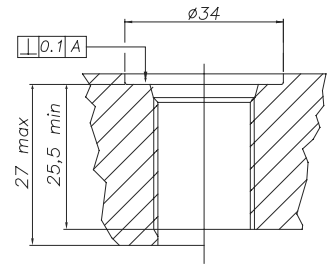

scala 5:1

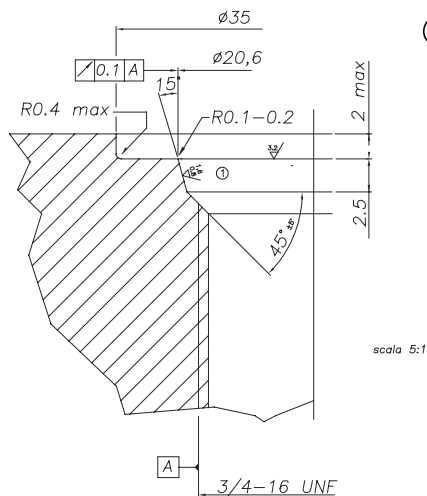

① THREAD 3/4"-16UNF

The sealing surface must be free from scratches longitudinal or spiral
 Ro 1.6 μm for sealing with NON-pulsating pressure
 Ro 0.8 μm for seals with pulsating pressure

Suggested o-ring:

PARKER 3-908 16,36x2,21
 Material: Viton 90° Shore-A
 Mixes: PARKER N552-90

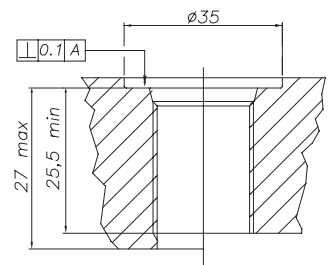

scala 5:1

ELECTRICAL CONNECTIONS

Function	CONNECTORS	
	WRG-A-A	WRG-A-B
	5 pin M12	6 pin M16
Output 1 (position) 0...10V 4...20mA	1	1
GND Output 1 (0V)	2	2
Output 2 (inverse position) 10...0V 20...4mA	3	3
GND Output 2 (0V)	2	4
Power supply +	5	5
Power supply GND	4	6
n.c.	-	-
n.c.	-	-

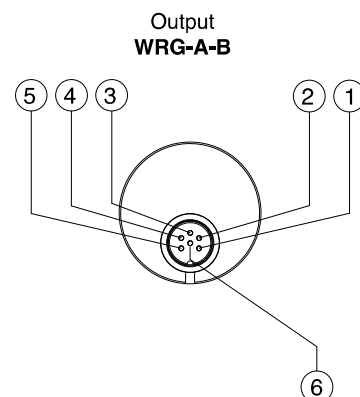
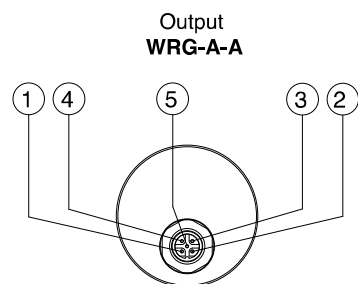

GROUNDING WRG-A

Connector output WRG-A

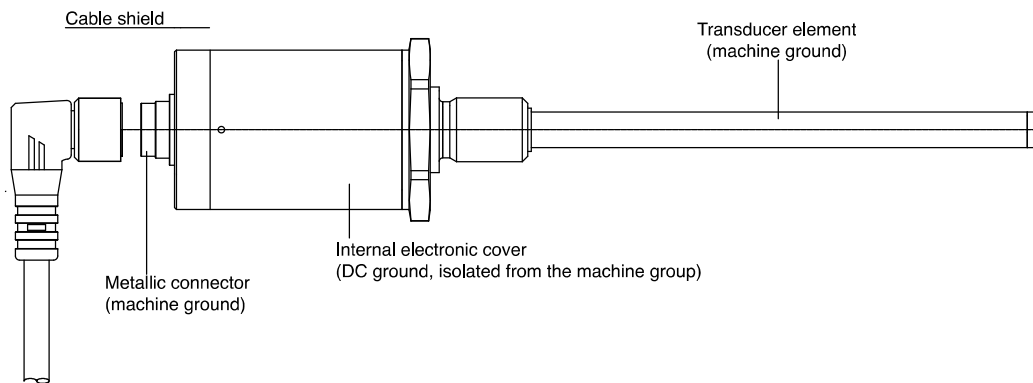

ANALOG OUTPUT

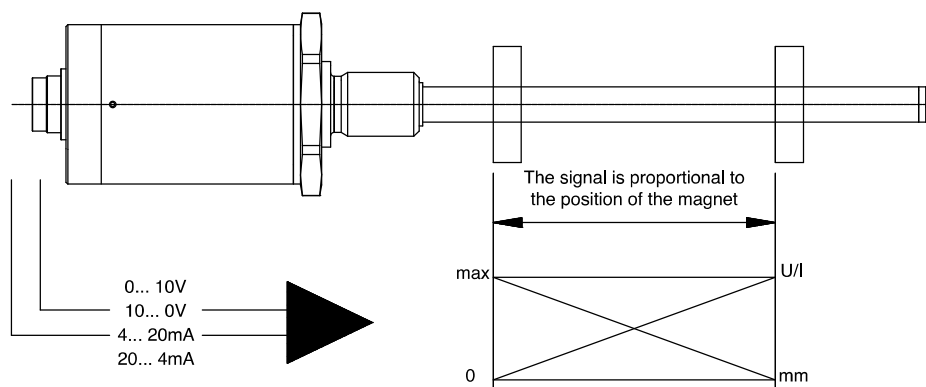

The magnetostrictive transducers of the WRG-A series supply a direct and reverse analogue output in voltage (0...10 / 10...0 Vcc) and current (4...20 mA / 20...4 mA). The outputs are direct, no signal conditioning is required if they are interfaced with a controller or measuring instrument.

ORDER CODE

Position transducer

W R G A [] [] [] [] [] [] [] [] 1

0 0 0 0 X X X X S [] [] [] 0 X X

Analog output **A**

Output Connector

M12 5 pin output connector **A**

6 pin DIN 45322 output connector **B**

MODEL

Output

0...10, 10...0 Vcc **A**

4...20, 20...4 mA **E**

0...20, 20...0 mA **G**

Cable lengths

Output F/R 1 mt	00
2 mt	02
3 mt	03
4 mt	04
5 mt	05
10 mt	10
15 mt	15
Output A/B/C/H	00

Thread

M 18x1.5 (standard)	M
3/4" - 16UNF	I

► Included in the supply

- Series WR position transducer
- OR 15.4 x 2.1 thread M18 x 1.5 cod: **GUA064**
- OR 16.36 x 2.21 thread 3/4" -16 UNF cod: **GUA065**

► Magnetic cursors must be ordered separately

Mechanical and/or electrical characteristics differing from those in the standard version may be arranged on request.

Ex.: **WRG-A-B-0400-A-1 0000XXXXS00M0XX**

Transducer model WRG, analog output, B connector, model 400mm, 0...10Vdc output, thread M18x1,5

FLOATING CURSOR



Cursors	
Cursor Diameter 32.8	095
Cursor Diameter 32.8 with 90° slit	096
Cursor Diameter 25.4	097
Floating cursor for liquids with hole diameter 12	098

The **PCUR095** is supplied with:
 N° 8 Brass nuts M4
 N° 8 Brass washers D4
 N° 4 Brass screws M4x25

The **PCUR096** is supplied with:
 N° 4 Brass nuts M4
 N° 4 Brass washers D4
 N° 2 Brass screws M4x25

Dimensions	A	B	C	D	Thickness
PCUR095	32.8	13.5	23.9	-	7.9
PCUR096				11	
PCUR097	25.4	13.5		-	

Model	PCUR098	
Length A	mm	52.4
Diameter B (hole)	mm	12
Diameter C	mm	44
Material		AISI 316

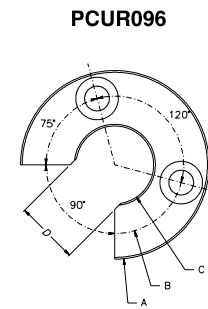
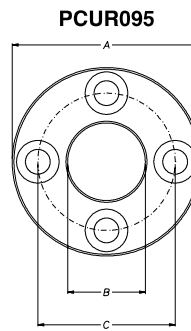

PCUR097

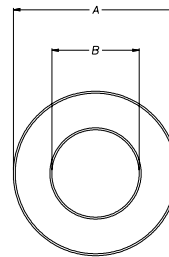

HEIGHT DETECTION POSITION

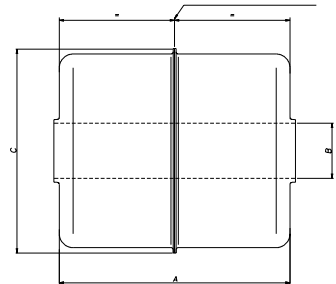

Note: PCUR098 is supplied with kit PKIT036 for floating cursor for liquids.

OPTIONAL CONNECTORS (to order separately)

For **WRG-A-A**, M12 thread connector
 CON031 and CON041 for 5 pin output (WRG-A-A)

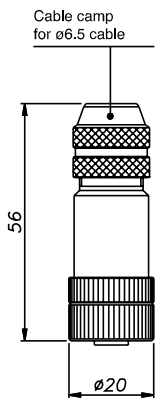

CON031
IP67 - IEC 48B

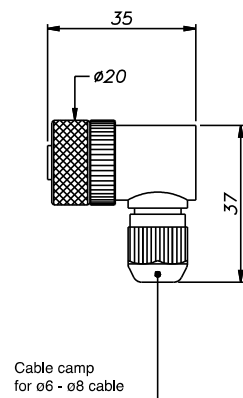

CON041
IP67

For **WRG-A-B**, M16 thread connector
 CON021, CON022 and CON023 for 6 pin output (WRG-A-B)

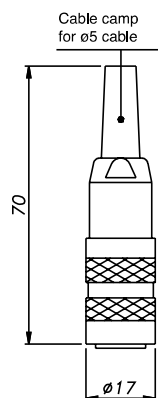

CON021
IP40 - EMC

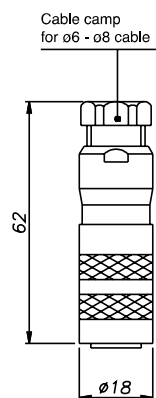

CON022
IP67 - EMC

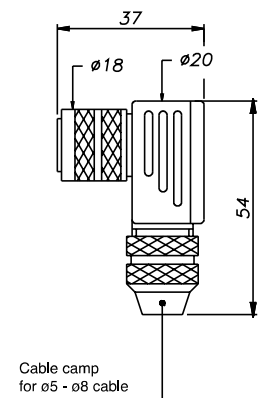

CON023
IP67 - EMC

OPTIONAL OUTPUT CABLES (to order separately)

For **WRG-A-A**, cable with connector (straight or 90°) with M12 thread 5 pin

Length "L"		CODE	
		Straight cable	Cable to 90°
2	mt	CAV011	CAV021
5	mt	CAV012	CAV022
10	mt	CAV013	CAV023
15	mt	CAV015	CAV024

ACCESSORIES (to order separately)

Non-magnetic spacer for mounting PCUR022 cursor

CUR022

Sensors are manufactured in compliance with:

- EMC 2014/30/EU compatibility directive
- RoHS 2011/65/EU

Electrical installation requirements and Conformity certificate are available on our web site: www.gefran.com

GEFRAN spa reserved the right to make aesthetic or functional changes at any time and without notice.