



Main application

- Packaging
- Extrusion
- Thermoforming
- Injection moulding
- Textile
- Multizone furnaces

Main features

4 independent loop control unit.
Compact, ready to use, equipped also with fieldbus interface.

Unit consisting of:

- Controller
- 30, 60, 80kW solid state relay
- Current transformers (one or four)
- Fuses-holder (option)
- 4 universal main inputs
- 4 heat/cool independent PID
- 4 main output internally wired to the SSR
- 4 auxiliary analog inputs (option)
- 4 configurable output (option):
relay / logic / TRIAC / continuous
- 2 configurable relay alarm output
- 2 digital inputs
- Standard digital communication:
Modbus RTU
- Optional Fieldbus communication:
Profibus DP, CANopen, DeviceNet,
Modbus RTU, Ethernet Modbus TCP
- DIN rail or panel mounting

PROFILE

GFX4 is a four independent loop controller, designed to manage electrical power. GFX4 is a compact unit bounding different technological elements like:

- controller
- solid state relay
- current transformers
- fuses-holders (option)

The final result is a cost saving in terms of space and cabling.

GFX4 consisting of:

- power management unit
- analog and digital inputs,
- analog and digital outputs
- standard digital communication
- integrated solid state relays
- fuses-holder (option)

Geflex controls autonomously the four loop controllers, furnishing a complete diagnostics like the loaded current, the control of the zones, the alarms state.

A specific step by step software tool has been develop in order to assist the product configuration based on the different applications.

Communication with the outside is of primary importance.

Geflex dialogs with the operator terminals according to the most popular protocols: from the simple and efficient Modbus to, by a second optional fieldbus communi-

cation, the by-now indispensable Profibus DP, CANopen, DeviceNet, Modbus RTU, Ethernet Modbus TCP.

The product's furnished with a standard configuration, simple and quickly to modify.

The assignment of different functions to the outputs is very simple.

MODELS

(see table in order code)

3 different sizes, depending on the electric power managed, are available.

GFX4 80

Maximum contemporaneous power up to 80kW@480V.

Each zone could reach up to 19,2 kW.

This limit could be extend to 23,7 kW using the "smart power management" (not all the zone contemporaneous).

Nominal current 40A for zone, not contemporary maximum 57A

GFX4 60

Maximum contemporaneous power up to 60kW@480V.

Each zone could reach up to 15,3 kW.

Nominal current 32A for zone

Fuse holder could be provide as an option.

GFX4 30

Maximum contemporaneous power up to 30kW@480V.

Each zone could reach up to 7,6 kW.

Nominal current 16A for zone

Fuse holder could be provide as an option.

INPUTS

Process analogue

4 universal process input could accept: thermocouple, thermoresistance, current and tension linear.

The type could be choose by software and no external converting device are required.

Digital

2 digital input.

The functionality could be selected within a wide range including setpoint selection, MAN/AUTO, alarm memory reset and many other.

Incorporated CT

From 1 to 4 CT control each zone and the relative alarm control is start up (HB..).

Auxiliary analogue (option)

4 further analogue inputs are available, typically for external current transformer reading.

OUTPUTS

Output alarms configurable via software.

Heating control

For each zone an heating control internally connected to power unit is present, then no further connections needed between power unit and controller.

Cooling control (option)

For each zone a cooling control is present 4 types of outputs are available: relay, logic, triac, continuous.

A current transformer is furnished with TRIAC output.

Alarms

Two relay output configurable as minimum and maximum alarm are available for each unit.

LEDs

Eight monitoring led are available in order to provide diagnostic information.

RN

RUN stet of the CPU

ER

Error

DI1

DI1 digital input state

DI2

DI2 digital input state

O1

Outupt 1 state

O2

Outupt 2 state

O3

Outupt 3 state

O4

Outupt 4 state

By default a different meaning is applicable.

POWER

Power is controlled with double SCR in anti-parallel, zero crossing switching principle, with configurable proportional cycle time.

Different load connection are available: monophas, dualphases, three-phases.

FUSES (OPTION)

The fuses are orderable on the GFX4 30KW and 60kW model.

Thanks to this, you save time, wiring is simplified, and dimensions in the panel are reduced.

PROGRAMMING

The Geflex modules can be programmed:

- using GFX-OP
- using Winstrum tool software
- using Industrial PC or PLC.

FUNCTIONS

Control

The Geflex control algorithm works with any type of thermal process.

Different control modes are available: from a simple ON/OFF control to PID single or double acting heat/cool (for cooling, simply indicate the fluid used).

Sophisticated and efficient automatic tuning algorithms for control parameters provide precise process control without the presence of an operator.

Alarms

There are 8 alarm assignable to each single canal or to all (AND / OR logic) and configurable as absolute, relative, direct, reverse, window, latching or not, inhibit at power-on.

Diagnostics

Geflex assures efficient process monitoring from a thermal and electrical point of view, allowing the operator to foresee breakdowns or malfunctions and take timely action (for example, in case the temperature safety limit is exceeded, broken probe, load fault).

The LBA alarm precisely checks the control loop, while the on-board current transformer (one always present, four available in option) lets you directly monitor load and trip the HB alarm in case of

current failure or SSR in short circuit.

Detection of short circuit or opening of input probe, open loop alarm (LBA), interrupted load alarm (HB).

Over temperature alarm

The software can be used to define the state of alarm outputs or a preset power level to be supplied in case of broken probe.

This assures continuity of service in the individual zone.

Tuning

- Self-tuning: calculation of PID parameters at system art.
- Auto-tuning continuous: continuous adjustment of PID
- Autotuning one-shot: output modulation and event-driven automatic PID parameters re-calculation

Special functions

- Soft-start: power parcellization time-based
- Software Off: disabling of the control, outputs are turned off
- Inputs\outputs: direct management of inputs/outputs, independently from internal firmware
- Simulation of four independent Geflex units.

STANDARD DIGITAL COMMUNICATION

The product is furnished with standard digital communication [PORT 1] used as GFX4 connection to a HMI or Industrial PC.

Also by a dedicated connector (10 pins) it's possible to connect the actual range of Geflex.

A second standard digital communication (PORT 2) configurable by most popular protocol:

CANopen

DeviceNet

Profibus DP

Modbus RTU

Ethernet Modbus TCP

is available as option.

Net address

Assigned by two rotative selectors.

GENERAL DESCRIPTION

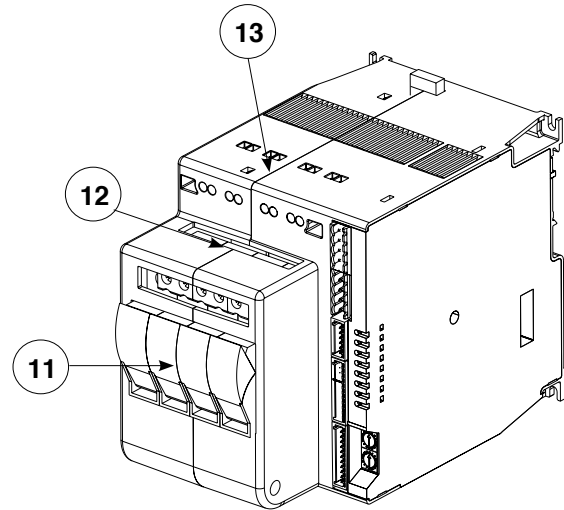
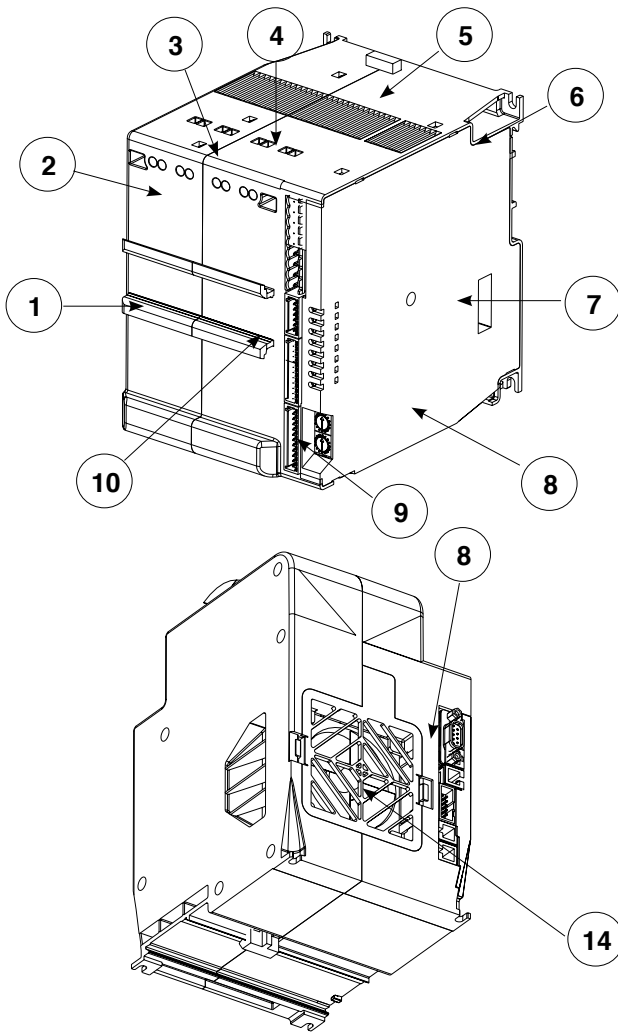

1. DIN rail frontal
2. power terminal: screws
3. power terminal
4. ventilation grid (attention NOT obstruct)
5. hook/release device back DIN rail
6. hole for screws
7. microswitches of configuration
8. standard digital communication
9. rotative selector switch
10. connectors J1, J2, J3, J4
11. fuses-holder (only for 30KW and 60KW models)
12. fuses-holder terminal (F1, F2, F3, F4)
13. power terminal (U1, U2, U3, U4)
14. ventilation grid (attention NOT obstruct)

DIMENSIONS - INSTALLATION

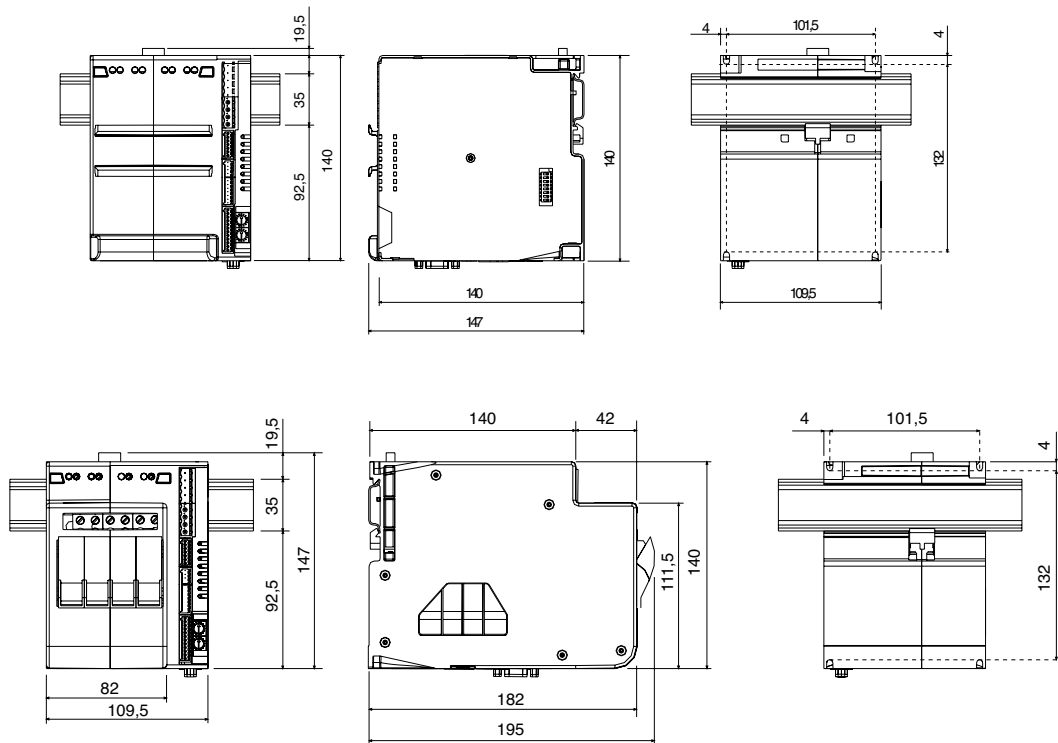

TECHNICAL DATA

INPUTS

IN1...IN4 [process analog inputs]

Connector: J4

Function

default process variable (configurable)

Sampling time

120msec the four inputs

Accuracy

0,2% FS \pm 1 steps at 25°C. (16000 points)

Thermal drift

0,005% FS/°C

Type

• *Thermocouples ITS90:*

J, K, R, S, T, custom (IEC584-1, CEI EN 60584-1, 60584-2).

Internal cold junction compensation with automatic compensation.

Selectable temperature range: °C/°F

• *Thermoresistance:* Pt100 DIN 43760

Max. resistance 20 Ω

Selectable temperature range: °C/°F

• *Voltage:* range 0/12...60mV, Ri > 1M Ω
0/0,2...1V, Ri > 1M Ω custom 60mV at 32 sections

• *Current:* range 0/4...20mA, Ri = 50 Ω
custom 20mA at 32 sections

IN5...IN8 [auxiliary analogue inputs]

Connector: J3

Function

default analog inputs reading

Sampling time

480msec for TC, voltage

Accuracy

1% FS \pm 1 steps at 25°C.

Type

• *Thermocouple ITS90:*

J, K, R, S, T, custom (IEC584-1, CEI EN 60584-1, 60584-2).

Internal cold junction compensation with automatic compensation.

• *Voltage:*
range 0/12...60mV, Ri > 1M Ω

IN9...IN12 [internal CT input]

Connector: internal connection

Function

default internal CT reading

Sampling time

60msec for CT

Accuracy

1% FS \pm 1 steps at 25°C.

Type

internal CT: 50mAac, 50/60Hz, Ri = 10 Ω

DI1, DI2 [digital inputs]

Connector: J2

Function

default not enable (configurable)

Type

PNP, 24Vdc, 8mA (isol. 3500V)

OUTPUTS

OUT 1...4 [heating control]

outputs connected to solid state relay

Function

default heating control (configurable)

OUT 5...8 [cooling control]

Connector: J1

Function

default cooling control (configurable)

Type

• Relay: NO, max 3A, 250V/30Vdc,
cos ϕ = 1, resistive load

• Logic: 24Vdc, 35mA

• Continuous:

• voltage: 0/2...10V, \pm 10V, max 25mA
short circuit protection

• current: 0/4...20mA, 500 Ω max

• insulation: 3500V

• Triac: 230V/4Amp AC51
(1A for four)
(2A for two)

OUT 9...10 [alarms]

Connector: J1a/J1

Function

default alarms (configurable)

Type

Relay: NO, max 5A, /30Vdc, cos ϕ = 1

LEDs

RN RUN state of the CPU

ER error

DI1 DI1 digital input state

DI2 DI2 digital input state

O1 Out.1 main input state

O2 Out.2 main input state

O3 Out.3 main input state

O4 Out.4 main input state

COMMUNICATION PORTS

PORT 1 [local bus]

Connectors: S1 / S2 / S3

Function: local bus

Protocol: Modbus RTU

Baud Rate: 115Kbps (default)
setting 1200...115Kbps

Node address: setting by double rotative selector

Connector S1 / S2: 2xRJ114/4, RS485 2 wires insul. 1500V

Connector S3: 10 pins for flat cable

SERIAL 2 [fieldbus]

Connectors: S4 / S5

Function

external fieldbus

Protocol

Modbus RTU _____ 115Kbps

CANopen _____ 10K...1Mbps

Profibus DP _____ 9,6...12Mbps

DeviceNet _____ 125K...500Kbps

Ethernet Modbus TCP 10/100Mbps

See accessories

MICROSWITCHES

8 dip switches are available to select wiring mode and different functionalities.

POWER

SSR [integrated power element]

Rated voltage: 480Vac

Work voltage range: 24...530Vac

Non-repetitive voltage: 1200Vp

Switching voltage for zero: < 20V

Rated frequency: 50/60Hz (self-adjusting)

Rated current AC51

GFX-4 30kW: 16Amp

GFX-4 60kW: 32Amp

GFX-4 80kW: 57Amp

Non-repetitive overcurrent [t=20msec]

GFX-4 30kW: 400A

GFX-4 60kW: 600A

GFX-4 80kW: 1150A

I_t for melt [t=1...10msec]

GFX-4 30kW: 645A²s

GFX-4 60kW: 1010A²s

GFX-4 80kW: 6600A²s

Dv/dt critical with deactivated output:

1000V/ μ sec

Rated insulation voltage In/Out:

4000V

GENERAL FEATURES

Power supply:

24Vdc \pm 25%, max 8VA

Protection class:

IP20

Working temperature range:

0...50°C (see dissipation curves)

Storage temperature range:

-20...+70°C

Relative humidity:

20...85% UR non-condensing

Installation:

EN50022 DIN rail or panel by screw

Dimensions:

see dimensions and installation

Weight:

models 30/60/80 = 1200g.

models 30/60 with fuse holders = 1600g.

ORDER CODE

Model GFX4	Current (Amp)		Voltage (Vac)			Power (kW)		
	max for channel		range	nominal	working	total contemporary	single channel	max for single channel
30 (4x16A)	16		24...530	480	110	(4x16x110) 7	(16x110) 1,7	(1x16x110) 1,7
					230	(4x16x230) 14,7	(16x230) 3,6	(1x16x230) 3,6
					400	(4x16x400) 25,6	(16x400) 6,4	(16x400) 6,4
					480	(4x16x480) 30,7	(16x480) 7,6	(1x16x480) 7,6
60 (4x32A) (4x30A)*	32 (30)*		24...530	480	110	(4x32x110) 14	(32x110) 3,5	(32x110) 3,5
					230	(4x32x230) 29,4	(32x230) 7,3	(1x32x230) 7,3
					400	(4x32x400) 51,2	(32x400) 12,8	(1x32x400) 12,8
					480	(4x32x480) 61,4	(32x480) 15,3	(1x32x480) 15,3
80 (4x40A)	40*	57	24...530	480	110	(4x40x110) 17,6	(40x110) 4,4	(1x57x110) 62,7
					230	(4x40x230) 36,8	(40x230) 9,2	(1x57x230) 13,1
					400	(4x40x400) 64	(40x400) 16	(1x57x400) 22,8
					480	(4x40x480) 76,8	(40x480) 19,2	(1x57x480) 27,3

* UL Certificate

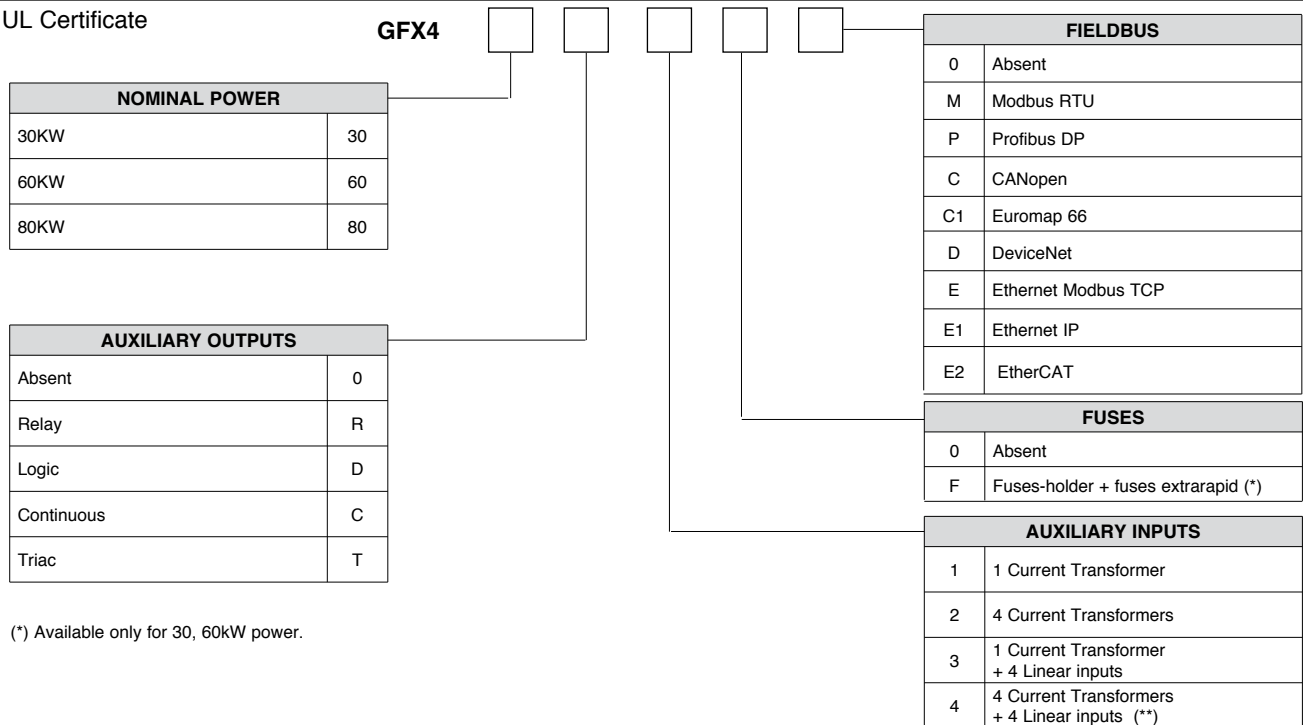

(*) Available only for 30, 60kW power.

(**) Option NOT available with Fieldbus E1 or E2

GEFRAN spa reserves the right to make aesthetic or functional changes at any time and without notice.



Conformity C/UL/US File no. E2433866



The instrument conforms to the European Directives 2004/108/CE and 2006/95/CE with reference to the generic standards:
EN 61326-1 (Product) EN 61010-1 (safety)

GEFRAN

GEFRAN spa via Sebina, 74 - 25050 Provaglio d'Iseo (BS)
Tel. 03098881 - fax 0309839063 - Internet: <http://www.gefran.com>

DTS_GFX4_09-2010_ENG